

F18

NAME _____
 DATE _____
 TRACK _____

TRACK CONDITION

SURFACE CARPET ASPHALT
 TRACTION
 LOW MEDIUM HIGH

DRIVE RATIO

PINION _____ SPUR _____
90

BALL DIFF. TRANSMISSION

LOSE TIGHT

TYRES	MODE	TYPE
FRONT	P-ONE	P01
REAR	P-ONE	P01

SPRINGS

FRONT		GREY	<input type="radio"/> G
REAR		GOLD	<input type="radio"/> GLD
DAMPER		RED	<input type="radio"/> R

OIL	VISCOSITY	PISTON HOLES
DAMPER	700	5 HOLES
SIDE SHOCK	100000	

REAR WING

<input checked="" type="checkbox"/>	①	LOW
<input type="checkbox"/>	②	MEDIUM
<input type="checkbox"/>	③	HIGH

REAR HEIGHT

-3 MM. -2 MM. -1 MM. 0 MM. +1 MM. +2 MM. +3 MM.

HEIGHT ADJUST.

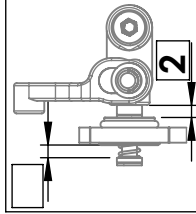

VIEW FROM TOP

CASTER

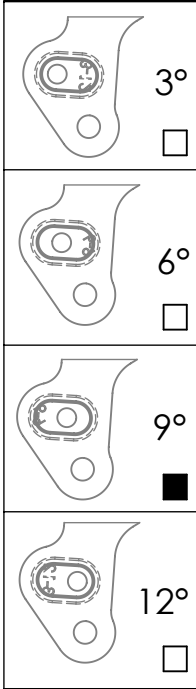

ACKERMANN

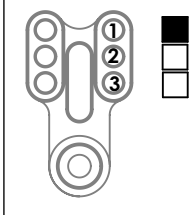

ABSORBER

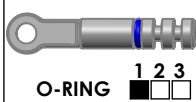

1° OUT IN TOE IN OUT 1°

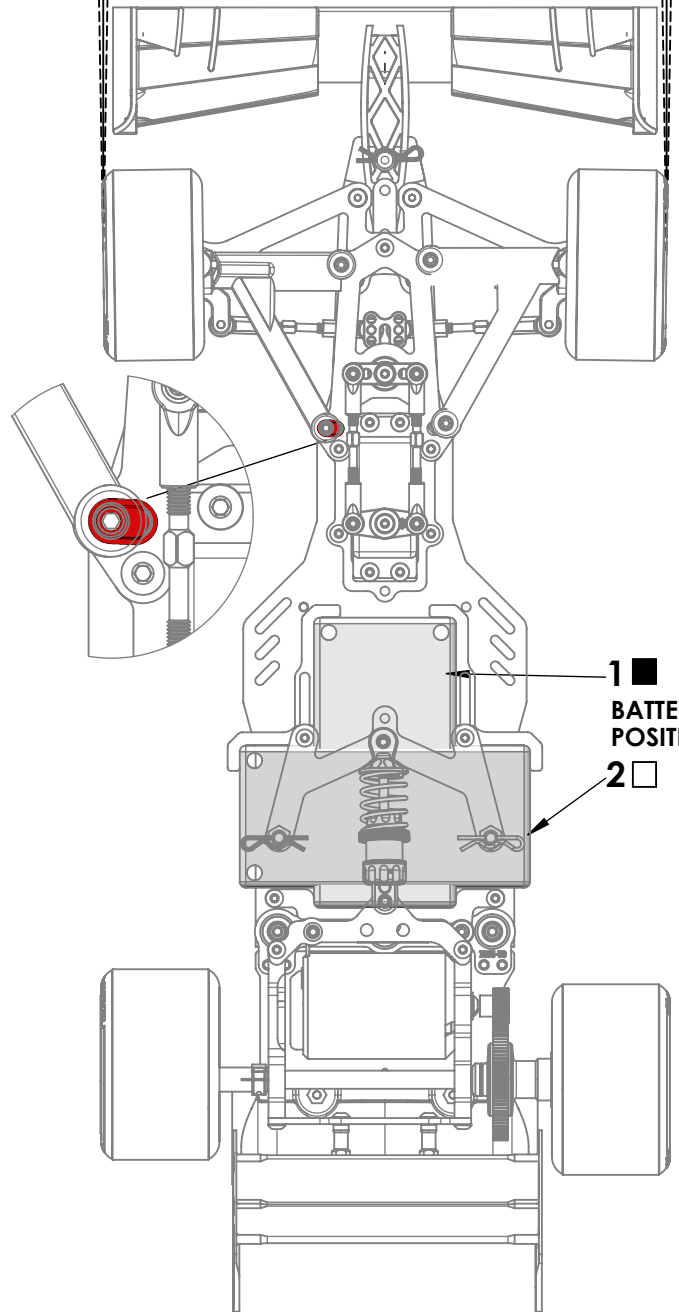

1 ■ BATTERY POSITION
2 □

1.5 + - FRONT CAMBER - + 1.5

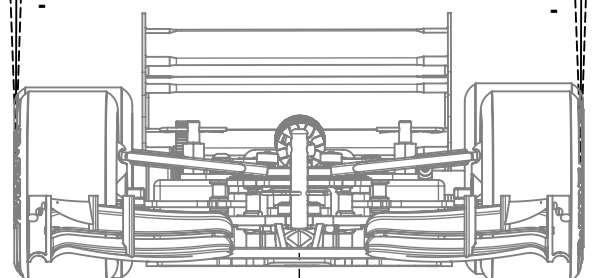

REAR WING POSITION

